

NOTE:

1. GYPSUM BOARD SHALL BE MOUNTED WITH STAGGERED SEAMS BETWEEN LAYERS, FINAL LAYER SHALL BE TAPED AND MUDDLED AT JOINTS.
2. ALL SEAMS AND PENETRATIONS SHALL BE CAULKED AIRTIGHT WITH ACOUSTICAL NON-HARDENING CAULK.
3. WALL SEAMS SHALL BE TAPED AND MUDDLED

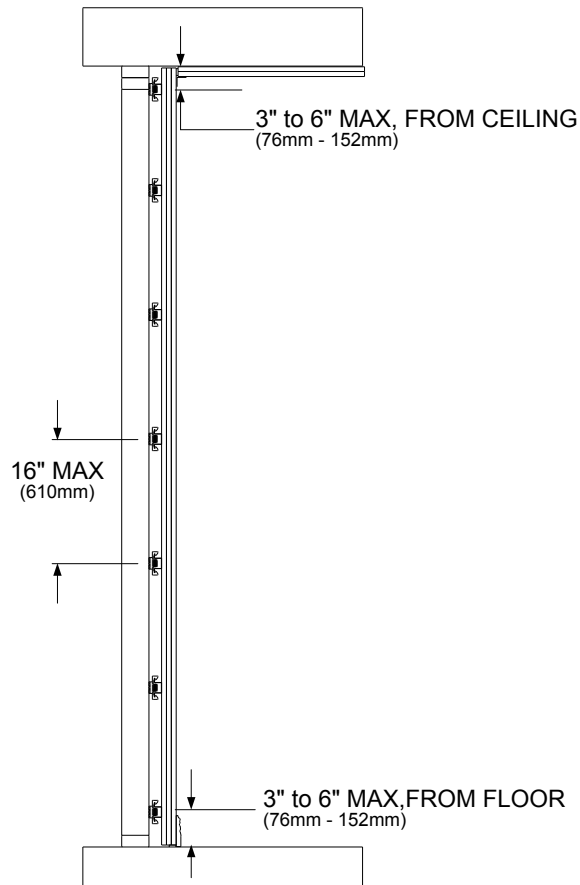

QuietClip CIC
@ 24" x 48" O.C.
STAGGERED LAYOUT, TYP.

7/8" FURRING CHANNEL,
25GA, TYP. (BY OTHERS)

WOOD OR STEEL
FRAMING, TYP.
(BY OTHERS)

RESERVE ISOLATED
GYP. 1/8"-1/4" FROM
FLOOR TO AVOID
SHORTING ASSEMBLY

CAULK SEAM AIRTIGHT
WITH NON-HARDENING
ACOUSTICAL CAULK.

RESERVE ISOLATED
GYP. 1/8"-1/4" FROM
STRUCTURE TO AVOID
SHORTING ASSEMBLY

QuietClip PIT-C02
2" x 1/4" FOAM STRIP,
ADHESIVE BACKED, TYP.

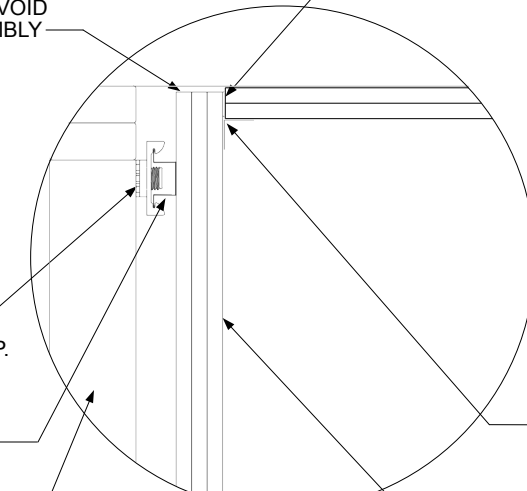

HEAD OF WALL

SEAM TO BE CAULKED
AIRTIGHT, TAPED AND
MUDDLED (BY OTHERS)

(3) LAYERS 5/8" GYP.
STAGGERED SEAMS,
TAPED & MUDDLED, TYP.
(BY OTHERS)

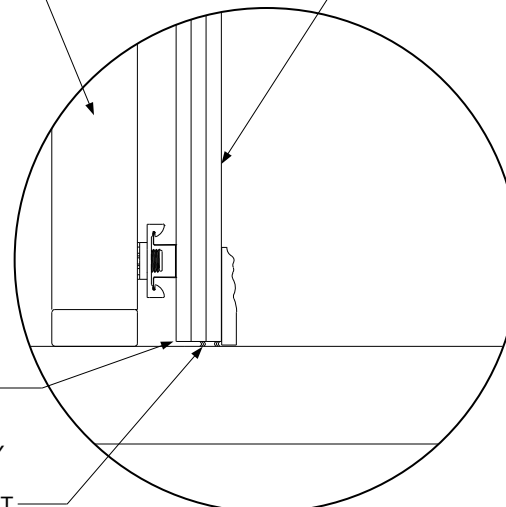

TOE OF WALL

SCALE: N.T.S.

SHEET 1/1